

Specialty Film & Sheet

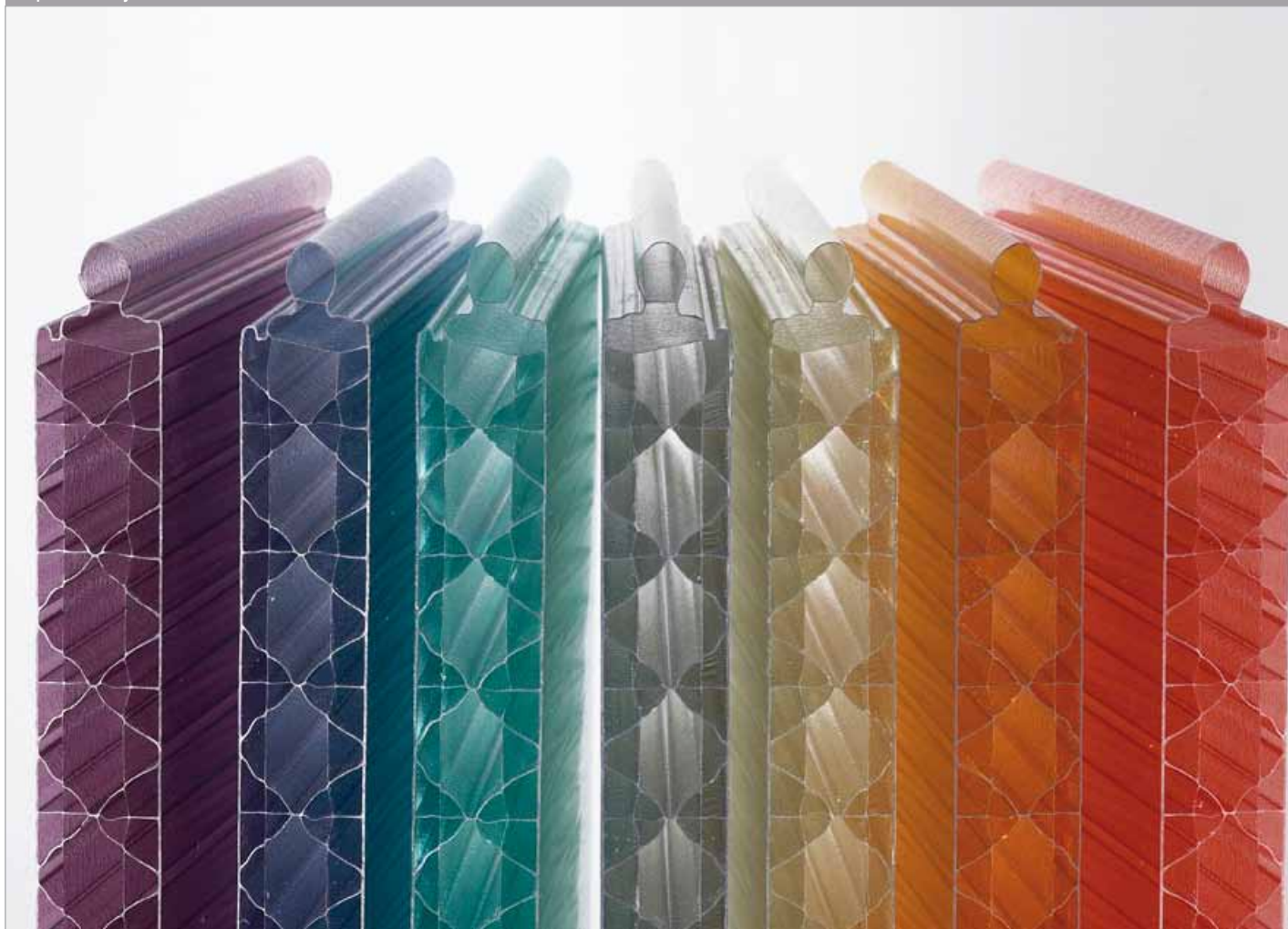

Lexan* Thermoclick* sheet
LTC404X4000 product technical manual



Content

Introduction 3

Lexan* Thermoclick* sheet Mechanical properties 5

General guidelines 6

Installation guidelines 6

Wind and Snow Loading 8

Installation guidelines 9



Lexan* polycarbonate

Lexan* polycarbonate is a unique engineering thermoplastic which combines a high level of mechanical, optical and thermal properties.

When extruded in multi-wall sheet form, its optical and impact properties in particular render this material a strong candidate for a wide range of glazing applications.

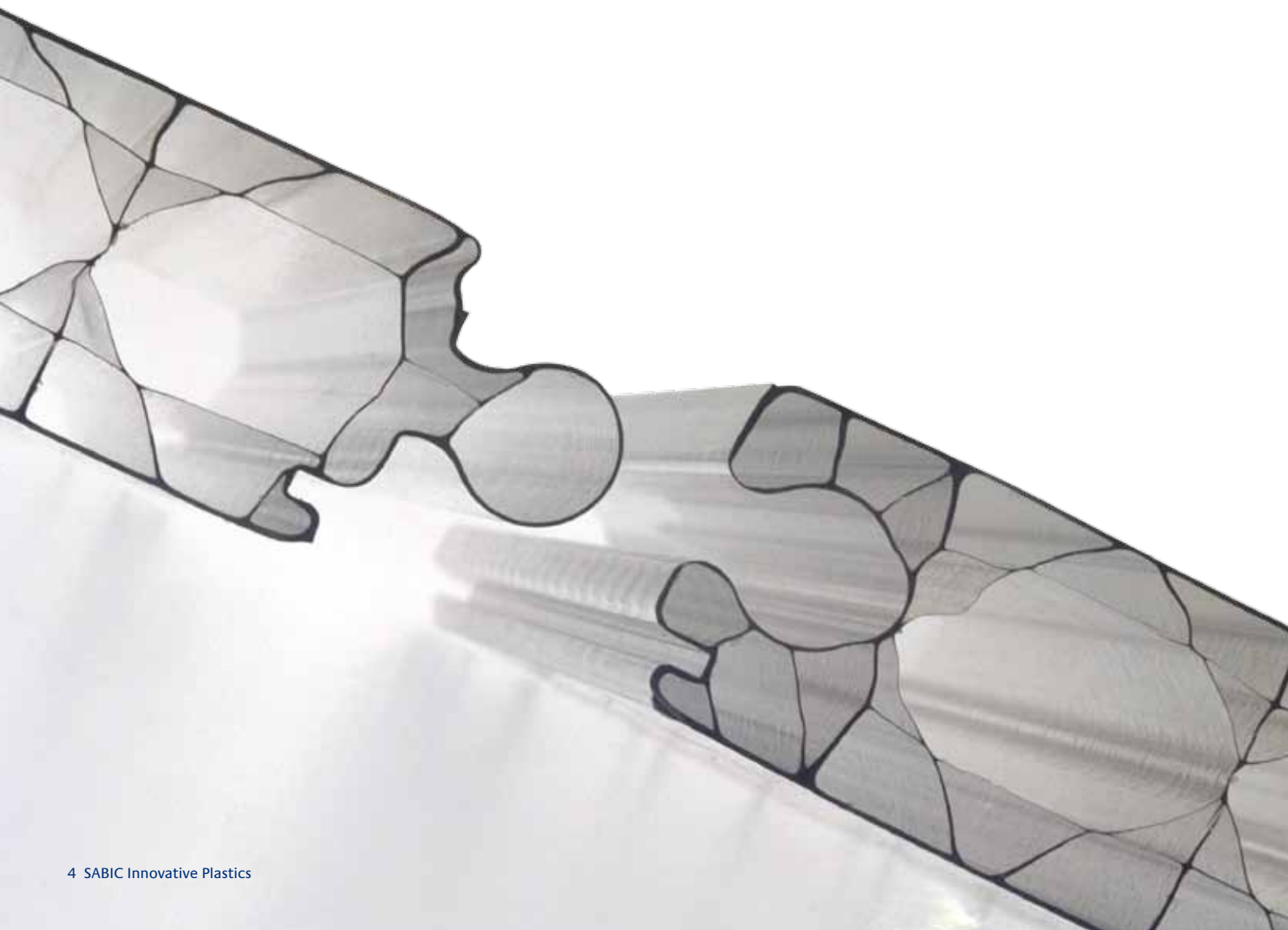

Lexan* Thermoclick* sheet

Lexan* Thermoclick* sheet LTC404X4000, is an impact resistant, energy-saving multi-wall sheet with profiled tongue and groove connection, including a groove for double sided tie on the inside. This inter-connecting system eliminates the need for vertical profiles, thereby saving costs and enhancing aesthetics.

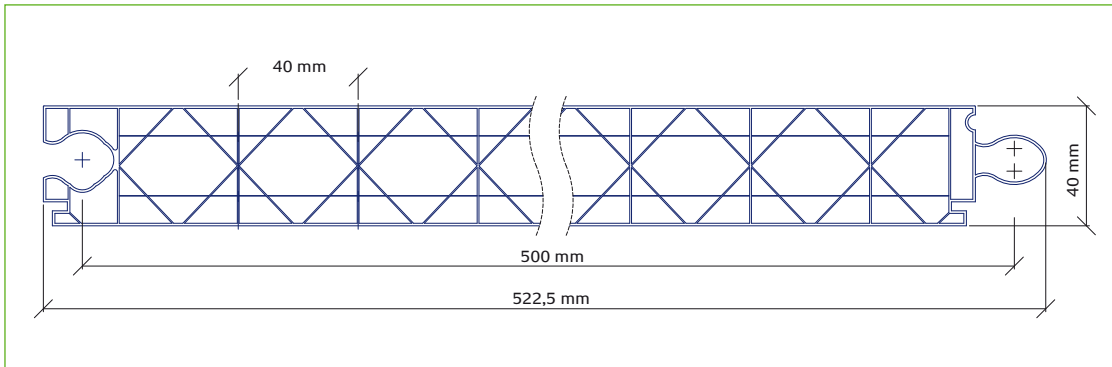

1.1

Lexan* Thermoclick* sheet LTC404X4000 offers

- Unique four wall with X-structure
- UV protected outer surface
- Good light transmission and light diffusion characteristics
- Extremely high stiffness
- Excellent thermal insulation
- High impact strength
- Long-term limited warranty weather resistance
- Easy and fast installation
- Wide range of colors and aesthetic effects

Property Profile	Value	Test Method
Panel width ctc	500 mm ±2.5 mm	
Standard length	≤ 6 meter -0 +20 mm > 6 meter -0 +30 mm	
Panel total thickness	40 mm ±0.8 mm	
Weight	4 kg/m ² ±5%	
Hail impact	diam. 20 mm v ≥ 21m/sec	TNO Test
Temperature resist.	-40 up to +100°C	UL 746 BEN
U-Value	1.41 W/m ² K	ISO 10077 (EN673)
Coeff. of linear thermal expansion	7 x 10 ⁻⁵ 1/°C	DIN 53752

Lexan Thermoclick sheet Mechanical properties

Impact Strength

Lexan Thermoclick sheet has outstanding impact performance over a wide temperature range of -40°C to +100°C. The product has been shown capable of withstanding many kinds of extreme weather, storms, hailstones, snowfall and ice formation.

Hail simulation

As a glazing material Lexan Thermoclick sheet is subject to extremes of weather; storms, hailstones, wind, snowfalls and ice formation. Under these conditions, the product is virtually unbreakable and is able to withstand the subsequent temperature change to sunny conditions without breaking or buckling.

In a test developed by the Dutch Testing Institute TNO, samples of Lexan Thermoclick sheet have been subjected to simulated hailstones of varying diameters without significant damage. Polyamide balls of varying diameters are shot at the surface of the Thermoclick sample using a pressurized airgun.

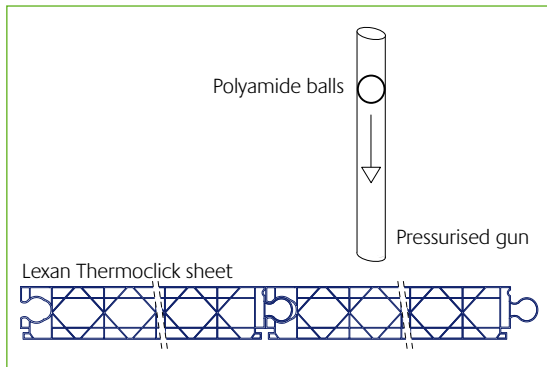

1.2

In practice, hailstones with a diameter of 20 mm can reach a terminal velocity of around 21 m/s. Under these conditions, traditional roof glazing materials such as glass and acrylic fail.

It should be noted that when the glass and the acrylic are tested, their failure characteristics are typically brittle, while the Lexan Thermoclick sheet shows ductile behavior - upon impact the ball will leave indentations but the sheet will not break.

Hail Simulation Test Results	Simulation
Material	Velocity with ball diameter 20 mm
Acrylic multi-wall sheet t=16 mm	7-14 m/s
Float glass t=4 mm	10 m/s
Lexan Thermoclick sheet t=40 mm	≥21 m/s
Equilibrium velocity of hail	21 m/s

UV protection

Lexan Thermoclick sheet has one proprietary UV protected surface to help protect the system against the degrading effects of ultra violet radiation of sunlight and promotes long-term optical quality under many kinds of severe weather conditions. This UV protected surface, indicated on the masking, should always face outwards.

Light / solar transmission properties

Solar heat gain within a building is caused by heat input from radiation emitted from the sun. Sunlight entering the building heats the air both directly and through absorption by the framework, furniture, etc. and is released as infrared energy. In combination with the insulating properties of Lexan Thermoclick sheet, this prevents heat escaping faster than it is created causing a temperature increase, the so-called 'green-house effect'. The temperature can be controlled by venting, often in combination with specially tinted opal white or Lexan Thermoclick Solar Control IR* sheet which contains a proprietary additive which selectively absorbs the near infrared region of the light. Lexan Thermoclick sheet is therefore available in many different colors or with IR additives which both cut down the brightness of sunlight to a pleasing level and reduces heat build up inside the building. Calculations for solar heat input through glazing are normally based on data published in "The Institution of Heating and Ventilating Engineers Guide Book". These calculations are based on clear glass and correction factors or shading coefficients and are then applied when alternative glazing materials are used.

Thermoclick colors

Color	Color	LT**	Direct ST**	Total ST***	Solar Heat Gain Coeff.#	Shading Coeff.##
LTC404X4000						
Clear	112	59%	56%	64%	0.64	0.73
Opal white	WH7A092X	50%	48%	57%	0.57	0.66
Blue	BL6C024T	20%	38%	51%	0.51	0.58
Green	GN7C018T	46%	44%	55%	0.55	0.63
Purple	VT5C010T	15%	41%	54%	0.54	0.62
Red	RD7C005T	27%	44%	56%	0.56	0.64
Orange	OR6C012T	34%	42%	59%	0.59	0.68
Yellow	YW9C007T	59%	52%	61%	0.61	0.70
LTCIR404X40						
Green	GN8B038T	38%	23%	40%	0.40	0.46
Grey	GY5B422T	14%	13%	32%	0.32	0.37
Blue	BL8B089T	23%	19%	37%	0.37	0.42

** Light Transmission (LT) and Direct Solar Transmission (Direct ST) acc. EN 410 as measured on 600 mm * 600 mm samples

*** Total Solar Transmission (Total ST) acc. EN 410 is the total solar energy that enters the interior of a building

Solar heat gain coefficient or g-value is the total solar energy that enters the interior of a building, divided by 100

Shading coefficient or b-value is the ratio of the total solar energy that enters the interior of a building with a given material and the total solar energy that enters the interior of a building with a standard 3 mm glass panel

SABIC Innovative Plastics offers a Ten Years Limited Warranty** on Lexan Thermoclick sheet covering loss of strength or impact due to weathering.

** SABIC Innovative Plastics offers a ten year limited written warranty on Lexan Thermoclick sheet covering discoloration, loss of light transmission and loss of impact strength due to weathering as more specifically defined in such warranty. Please consult your local distributor or SABIC Innovative Plastics' Sales Office for more details.

Thermal insulation

The multi-wall structure of Lexan Thermoclick sheet offers potential advantages where thermal insulation is a major consideration. The amount of energy transmitted through the material per square meter and per degree temperature difference, referred to as U-Value, is only 1.41 W/m²K.

Temperature resistance

Lexan Thermoclick sheet is characterized by its excellent retention of impact strength and stiffness at elevated temperatures, even over an extended period. Lexan Thermoclick sheet has a continuous use temperature rating of -40°C up to +100°C.

Fire test performance

Lexan Thermoclick sheet has good fire performance in accordance with many national fire standards. More detailed information is available from SABIC Innovative Plastics' service center or your local authorized dealer.

Storage

Lexan Thermoclick sheet should be stored and protected against atmospheric influences like sun, rain, etc. Care should be exercised when handling and transporting Lexan Thermoclick sheet in order to prevent scratches on the panel surface and damage to the panel edges.

Sawing

Lexan Thermoclick sheet can be cut easily and accurately with most standard workshop equipment. This includes common circular, hand and hacksaws both with fine-toothed blades. The panel should be clamped to the worktable to avoid undesirable vibration and the sawdust should be blown out of the channels.

Installation guidelines

Sealing recommendations

In order to minimize moisture build-up and dust contamination inside the channels, edge sealing of the open ended channels is very important. An impermeable tape and a perforating venting tape have been developed by the company Multifoil. Both tapes are available via your local authorized dealer.

Standard glazing

For standard glazing applications it is generally recommended to seal the top end channels with an impermeable tape and the bottom end channels with an anti-condensation venting tape. A clearance between the bottom panel end and the sash profile platform helps allow for condensation drainage.

Specific conditions

In extremely dusty environments such as sawmills, welding stations, etc., it is usually advisable to seal both the top and bottom channel ends with an impermeable tape.

Thermal expansion allowance

Take into account a clearance of approximately 3 mm per linear meter between panel top edge and top glazing profile platform, and between the first and last panel side and side glazing profile platform. This thermal expansion clearance is already taken into account when using the special developed top and bottom glazing profiles indicated in this chapter.

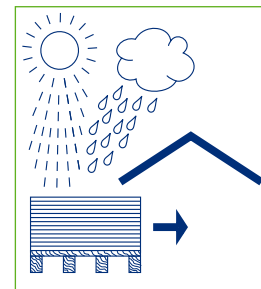

1.2

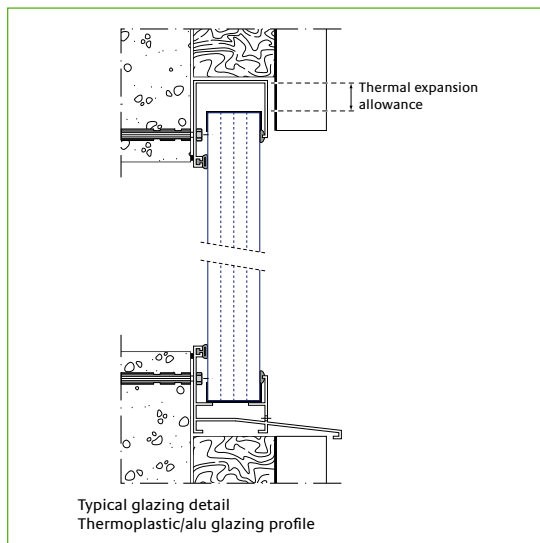

1.3

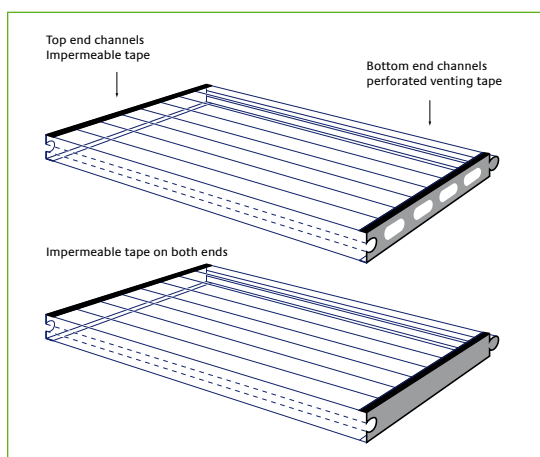

1.4

These cleaning recommendations apply to all Lexan polycarbonate sheet products, including, but not limited to, Lexan solid sheet and signs, Lexan coated Margard* sheet and Lexan multiwall sheet.

Periodic cleaning using correct procedures can help to prolong service life. For cleaning, it is recommended that the following instructions be adhered to:

Cleaning Procedure for Small Areas – Manual

1. Gently wash sheet with a solution of mild soap and lukewarm water, using a soft, grid-free cloth or sponge to loosen any dirt or grime.
2. Fresh paint splashes, grease and smeared glazing compounds can be removed easily before drying by rubbing lightly with a soft cloth using petroleum ether (BP65), hexane or heptane. Afterwards, wash the sheet using mild soap and lukewarm water.
3. Scratches and minor abrasions can be minimized by using a mild automobile polish. We suggest that a test be made on a small area of Lexan sheet with the polish selected and that the polish manufacturer's instructions be followed, prior to using the polish on the entire sheet.
4. Finally, thoroughly rinse with clean water to remove any cleaner residue and dry the surface with a soft cloth to prevent water spotting.

Cleaning Procedure for Large Areas - Automated

1. Clean the surface using a high-pressure water cleaner (max. 100bar or 1,450psi) and/or a steam cleaner. We suggest that a test be made on a small area, prior to cleaning the entire sheet.
2. Use of additives to the water and/or steam should be avoided.

Other Important Instructions for All Lexan sheets:

- Never use abrasive or highly alkaline cleaner on Lexan polycarbonate materials.
- Never use aromatic or halogenated solvents like toluene, benzene, gasoline, acetone or carbon tetrachloride on Lexan polycarbonate materials.
- Use of incompatible cleaning materials with Lexan sheet can cause structural and/or surface damage.
- Contact with harsh solvents such as methyl ethyl ketone (MEK) or hydrochloric acid can result in surface degradation and possible crazing of Lexan sheet.
- Never scrub with brushes, steel wool or other abrasive materials.
- Never use squeegees, razorblades or other sharp instruments to remove deposits or spots.
- Do not clean Lexan polycarbonate in direct sunlight or at high temperatures as this can lead to staining.
- For all mentioned chemicals consult the manufacturer's material safety datasheet (MSDS) for proper safety precautions.

Additional Important Considerations for Multiwall, Corrugated and Sign sheet:

- Cleaners and solvents generally recommended for use on polycarbonate are not necessarily compatible with the UV-protected surfaces of Lexan multiwall, corrugated and sign polycarbonate materials.
- Do not use alcohols on the UV-protected surfaces of Lexan sheet.
- Never clean the Drippgard surface of Lexan multiwall and corrugated sheets



Dynamic wind pressure

The wind speed is used to determine the actual loading upon the glazing panels. In mathematical terms, the pressure loading is calculated by multiplying the square of the design wind speed by 0.613.

$$p = KV^2$$

Where p = dynamic wind pressure in N/m² K = 0.613
 V = design wind speed in meters/second

Values of p in SI units (N/m²)

Wind speed	Wind pressure	Wind speed	Wind pressure
m/s	N/m ²	m/s	N/m ²
10	61	40	981
15	138	45	1240
20	245	50	1530
25	383	55	1850
30	552	60	2210
35	751	65	2590

The Beaufort scale transforms wind into static pressure

Wind	Light	Moderate	Strong	Storm
Speed (km/h)	20	40-60	80-100	120-140
Speed (m/sec)	6	11-17	22-28	33-39
Static pressure (N/m ²)	20	80-170	300-480	680-950

Pressure coefficient

To allow for local fluctuations in the acceleration/deceleration of the wind by building or glazing geometry, it is necessary to include an appropriate pressure coefficient. Determining pressure coefficients requires knowledge of

- Form and type of building
- Height of glazing
- Shape of glazing e.g.
 - flat vertical
 - inclined roofing
 - curved glazing

The wind loading is obtained by multiplying the dynamic wind pressure by the pressure coefficient. The total wind loading can be positive indicating a wind pressure load or negative indicating a wind suction load. Detailed pressure coefficient values can be found in the appropriate national building norms.

Snow loading

Snow loading on the roof glazings can be considered equivalent to a vertically, uniformly distributed load, acting per m² of the horizontal projection of the glazing. A roof made of Lexan Thermoclick sheet does not permit immediate melting of the snow, due to its excellent thermal insulation, and therefore the load produced by the snow must be carefully taken into consideration.

Indicative snow weights per centimeter of height are as follows

- fresh snowfall - 0.8-1.9 kg/m² per cmh
- wet snowfall - 2.8 kg/m² per cmh

Snow loading factors can be obtained from the appropriate local building norm.



Vertical wall glazing

This chapter illustrates some glazing proposals using commercially available aluminum glazing profiles which have been proven to be successful in combination with Lexan Thermoclick sheet. A wide range of easy to use aluminum glazing profiles and metal fastener clips are available at the vast majority of authorized Lexan Thermoclick sheet distributors and specialized installers. Lexan Thermoclick sheet can be installed either from inside the building or from the outside.

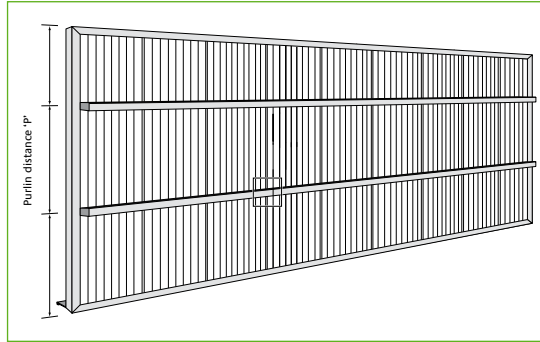

1.6

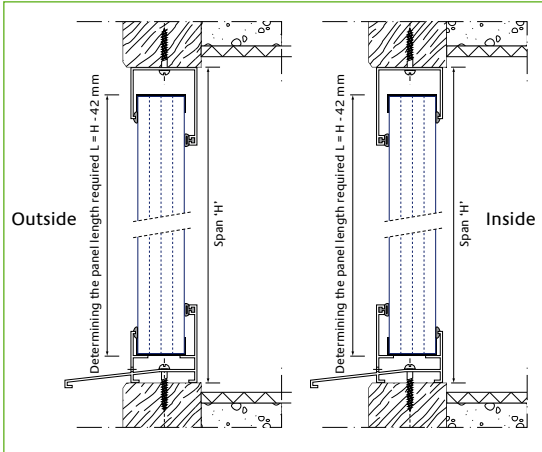

1.5

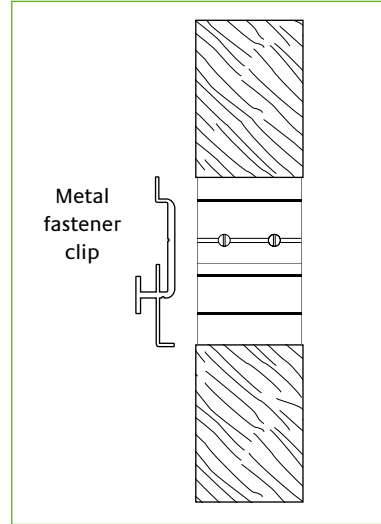

1.7

Maximum recommended span 'H'

Lexan Thermoclick sheet glazing recommendations without intermediate purlins.

Wind pressure / suction, in N/m ²	Maximum recommended span 'H' in mm
600	2500
900	2250
1200	2000
1500	1750
1800	1500

When the glazing height exceeds the maximum recommended span 'H', intermediate purlins should be used to support the Lexan Thermoclick sheet. Lexan Thermoclick sheet may be fixed to these purlins using special non-rusting metal fastening clips positioned in the double sided tie on both panel sides. The distance between the horizontal intermediate purlins should not exceed the maximum recommended span dimensions 'P' as indicated in the table below.

Maximum recommended span 'P'

Lexan Thermoclick sheet glazing recommendations with intermediate purlins and clip length of 100 mm.

Wind pressure / suction, in N/m ²	Maximum recommended span 'P' in mm
600	2500
900	2200
1200	2000
1500	1800
1800	1500

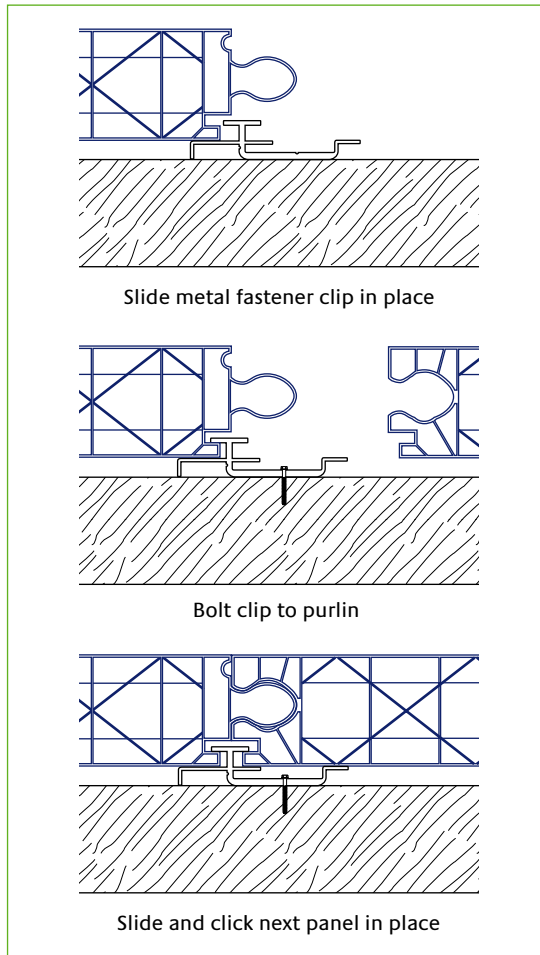

1.8

Alternative for connecting panels

Using the aluminum top and bottom glazing profiles, bolted to the intermediate purlins is a good alternative for connecting Lexan Thermoclick sheet when the glazing height exceeds the maximum allowable span 'H'.

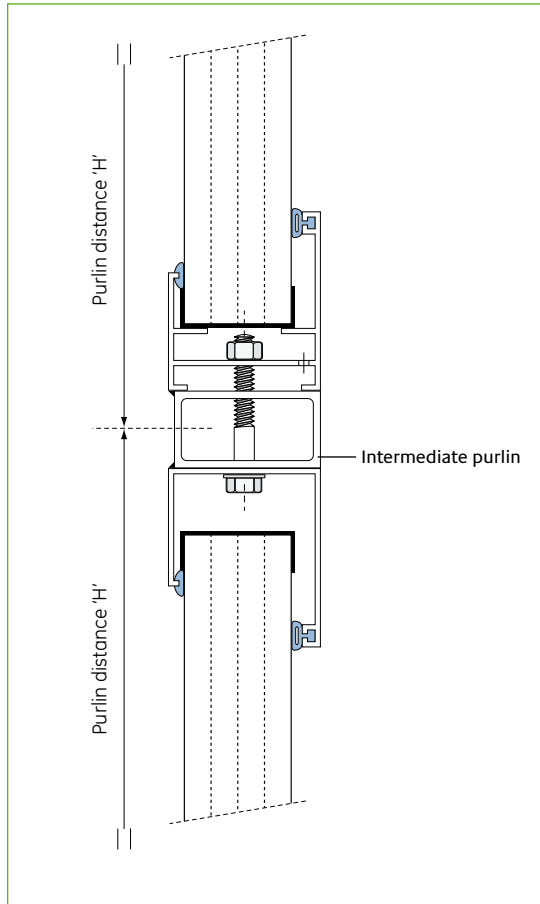

1.9



Americas:

SABIC Innovative Plastics
Specialty Film & Sheet
One Plastics Avenue
Pittsfield, MA 01201
USA
T +1 413 448 7110
F +1 413 448 5573

Europe:

SABIC Innovative Plastics
Specialty Film & Sheet
Plasticslaan 1
4612 PX Bergen op Zoom
The Netherlands
T +31 164 292911
F +31 164 292940

Pacific:

SABIC Innovative Plastics
Specialty Film & Sheet
1468 Nanjing Road (W)
26th Floor, United Plaza
200040 Shanghai
China
T +86 21 3222 4500
F +86 21 6289 8998

email: sfs.info@sabic-ip.com

THE MATERIALS, PRODUCTS AND SERVICES OF SABIC INNOVATIVE PLASTICS HOLDING BV, ITS SUBSIDIARIES AND AFFILIATES ("SELLER"), ARE SOLD SUBJECT TO SELLER'S STANDARD CONDITIONS OF SALE, WHICH CAN BE FOUND AT <http://www.sabic-ip.com> AND ARE AVAILABLE UPON REQUEST. ALTHOUGH ANY INFORMATION OR RECOMMENDATION CONTAINED HEREIN IS GIVEN IN GOOD FAITH, SELLER MAKES NO WARRANTY OR GUARANTEE, EXPRESS OR IMPLIED, (i) THAT THE RESULTS DESCRIBED HEREIN WILL BE OBTAINED UNDER END-USE CONDITIONS, OR (ii) AS TO THE EFFECTIVENESS OR SAFETY OF ANY DESIGN INCORPORATING SELLER'S PRODUCTS, SERVICES OR RECOMMENDATIONS. EXCEPT AS PROVIDED IN SELLER'S STANDARD CONDITIONS OF SALE, SELLER SHALL NOT BE RESPONSIBLE FOR ANY LOSS RESULTING FROM ANY USE OF ITS PRODUCTS OR SERVICES DESCRIBED HEREIN. Each user is responsible for making its own determination as to the suitability of Seller's products, services or recommendations for the user's particular use through appropriate end-use testing and analysis. Nothing in any document or oral statement shall be deemed to alter or waive any provision of Seller's Standard Conditions of Sale or this Disclaimer, unless it is specifically agreed to in a writing signed by Seller. No statement by Seller concerning a possible use of any product, service or design is intended, or should be construed, to grant any license under any patent or other intellectual property right of Seller or as a recommendation for the use of such product, service or design in a manner that infringes any patent or other intellectual property right.

SABIC Innovative Plastics is a trademark of SABIC Holding Europe B.V.

* Trademark of SABIC Innovative Plastics IP B.V.

©2008 SABIC Holding Europe B.V.

All Rights Reserved